

APPLICATION INSTRUCTIONS

BRACKET ASSEMBLY

Make complete Bracket Assemblies with the ease of only a few accessories. Securely mount tray and hang from ceilings, walls, and even off other brackets. (WMCBKT) (WMLBKT) (WMTSC) (WMTSL) (WMOMG)

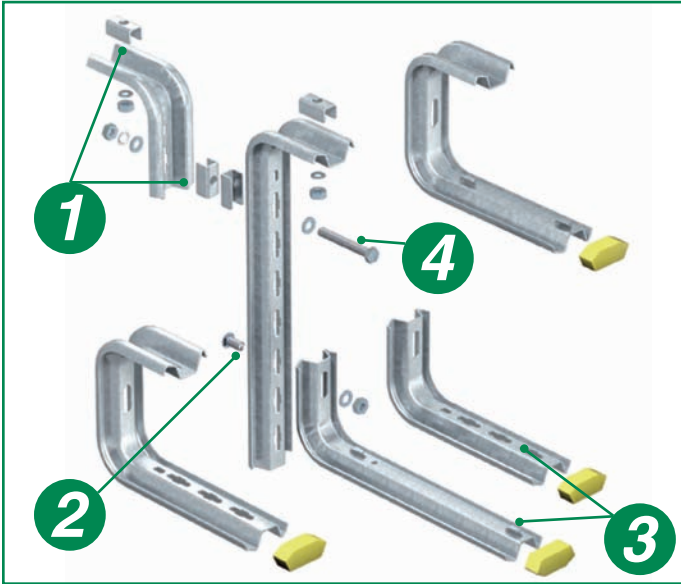

1

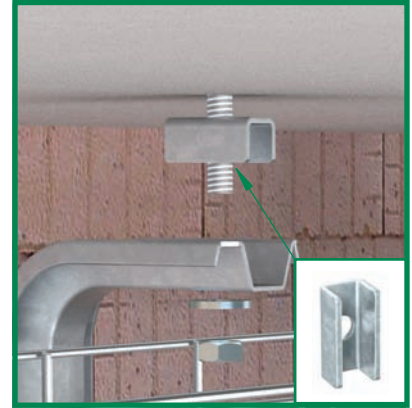

Spacer (WMSpacer) is used when mounting to the ceiling, wall, or when connecting two brackets back to back.

2

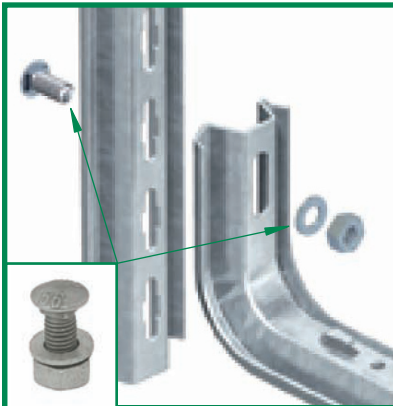

Secure brackets to one another using Nested Bolting Kits (WMNBKITS).

3

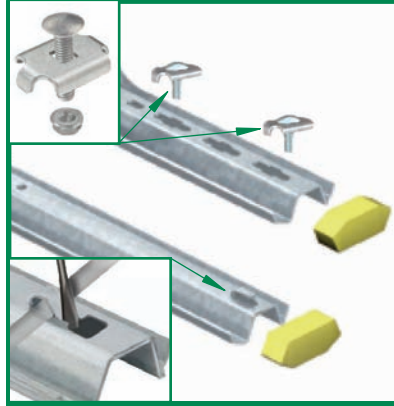

Anchor tray to brackets using Bolt Assemblies (WMBC250), Hold Down Clamp (WMHDC), or Chalfant's Tab System Brackets.

4

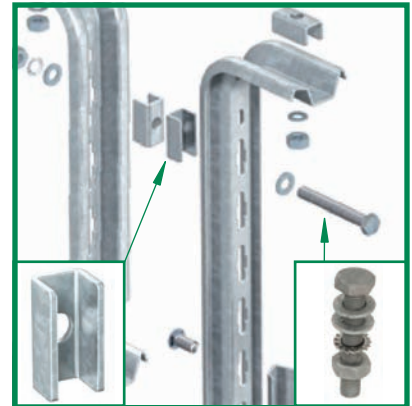

Secure two brackets to one another back to back using two Spacers (WMSpacers) and a Back to Back Bolting Kit (WMBBBKIT).

THIS DOCUMENT CONTAINS PROPRIETARY INFORMATION AND IS THE PROPERTY OF CHALFANT MANUFACTURING COMPANY. THE CONTENTS OF THIS DOCUMENT SHALL NOT BE DISCLOSED, COPIED AND OR PUBLISHED WITHOUT THE WRITTEN CONSENT OF CHALFANT MANUFACTURING COMPANY.

CHALFANT
Manufacturing Company

50 Pearl Road, Suite 212
Brunswick, OH. 44212
Phone: (330) 273-3510, Fax: (330) 273-8149
Web: www.ChalfantCableTray.com
Email: Sales@ChalfantCableTray.com