

PRODUCT SPECIFICATIONS:

	PART NUMBER	FINISH
10mm Hole	WMHDC10S	ELECTRO-GALVANIZED
10mm Hole	WMHDC10G	HOT DIPPED
10mm Hole	WMHDC10T	STAINLESS STEEL 304
6mm Hole	WMHDC06S	ELECTRO-GALVANIZED
6mm Hole	WMHDC06G	STAINLESS STEEL 304



RECOMMENDING MOUNTING:

1. FOR MOUNTING WIRE MESH TRAY.

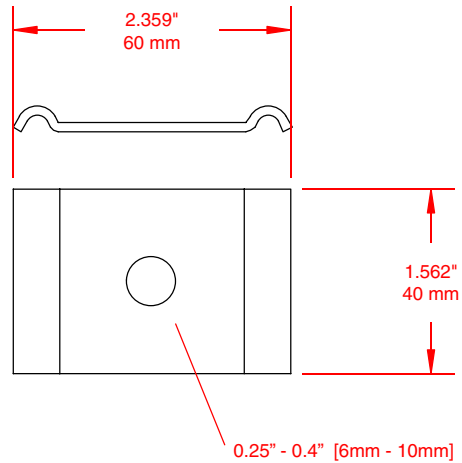

THIS DOCUMENT CONTAINS PROPRIETARY INFORMATION AND IS THE PROPERTY OF CHALFANT MANUFACTURING COMPANY. THE CONTENTS OF THIS DOCUMENT SHALL NOT BE DISCLOSED, COPIED AND OR PUBLISHED WITHOUT THE WRITTEN CONSENT OF CHALFANT MANUFACTURING COMPANY.

FILENAME: CDWMHDC10S		 50 Pearl Rd, Brunswick, OH. 44212 Phone: (800) 365-0228 Fax: (330) 273-8149 www.chalfantcabletray.com	HOLD DOWN CLAMP
SCALE: AS NOTED			
DRAWN: W.H.G.	02/20/01	PART NO. : AS IN TABLE	DRAWING NO. : WMHDCxxx
APPROVED:	C.D.: 0247		
REV.	SHEET 1 OF 1		