

PRODUCT SPECIFICATIONS:

1. MATERIAL: PRE GALVANIZED STEEL

TRAY WIDTH		BRACKET LENGTH (L)		PART NUMBER
Inchs.	[mm]	Inchs.	[mm]	
4	100	6	156	WMTSC04
6	150	8	206	WMTSC06
8	200	10	256	WMTSC08
12	300	14	356	WMTSC12

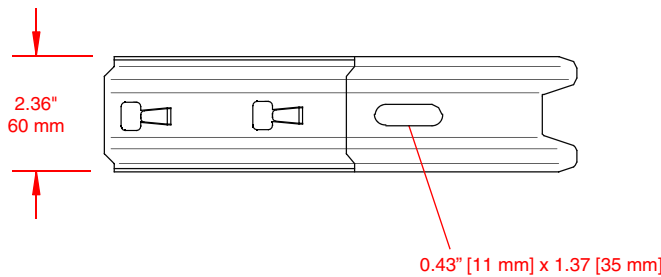
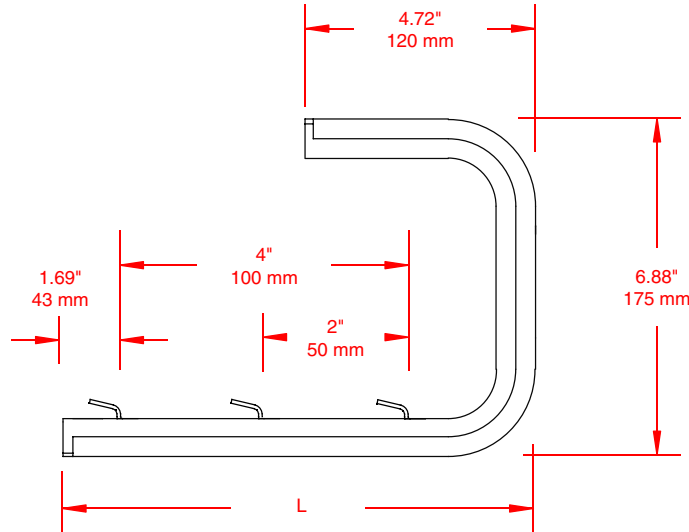

ISO 9001



THIS DOCUMENT CONTAINS PROPRIETARY INFORMATION AND IS THE PROPERTY OF CHALFANT MANUFACTURING COMPANY. THE CONTENTS OF THIS DOCUMENT SHALL NOT BE DISCLOSED, COPIED AND OR PUBLISHED WITHOUT THE WRITTEN CONSENT OF CHALFANT MANUFACTURING COMPANY.

FILENAME: CDWMTSC04		 50 Pearl Rd, Brunswick, OH. 44212 Phone: (800) 365-0228 Fax: (330) 273-8149 www.chalfantcabletray.com	"C" BRACKETS
SCALE: AS NOTED			
DRAWN: J.A.B	01/23/01	PART NO. : AS IN TABLE	DRAWING NO. : WMTSCxx
APPROVED: -	C.D.: 0162		
REV. -	-	SHEET 1 OF 1	