

PRODUCT SPECIFICATIONS:

1. MATERIAL: PRE GALVANIZED STEEL

BRACKET LENGTH (L)		PART NUMBER
Inchs.	[mm]	
18	445	WMEBKT18
22	545	WMEBKT22
26	645	WMEBKT26

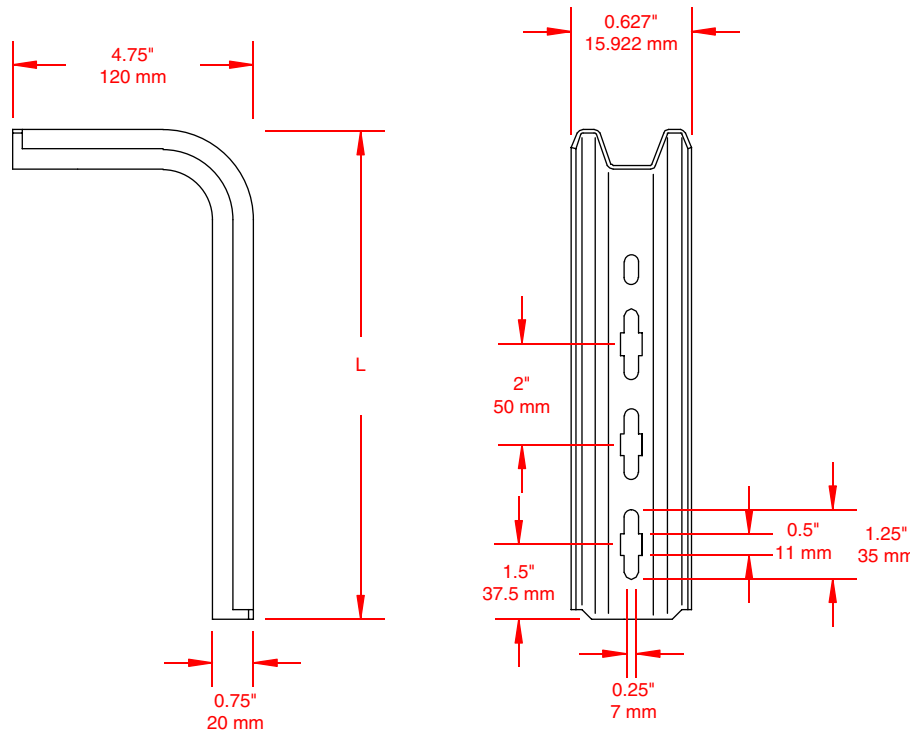

RECOMMENDING MOUNTING:

1. FOR MOUNTING TO HORIZONTAL CONCRETE CEILINGS, WALLS AND BRICKWORK.
2. USE WMSPACER FOR MOUNTING AGAINST SOLID SURFACES.



THIS DOCUMENT CONTAINS PROPRIETARY INFORMATION AND IS THE PROPERTY OF CHALFANT MANUFACTURING COMPANY. THE CONTENTS OF THIS DOCUMENT SHALL NOT BE DISCLOSED, COPIED AND OR PUBLISHED WITHOUT THE WRITTEN CONSENT OF CHALFANT MANUFACTURING COMPANY.

FILENAME: CDWMEBKT		 50 Pearl Rd, Brunswick, OH. 44212 Phone: (800) 365-0228 Fax: (330) 273-8149 www.chalfantcabletray.com
SCALE: AS NOTED		
DRAWN: J.A.B	01/23/01	PART NO. : AS IN TABLE
APPROVED: -	C.D.: 0162	
REV. -	-	SHEET 1 OF 1

EXTENDER BRACKETS

DRAWING NO. : WMEBKTxx