

**PRODUCT SPECIFICATIONS:**

PART NUMBER	FINISH
WMBSS	ELECTRO-GALVANIZED
WMBSG	HOT DIPPED
WMBST	STAINLESS STEEL 304
WMBSZ	STAINLESS STEEL 316



**RECOMMENDING MOUNTING:**

1. FOR BARRIER STRIP MOUNTING IN WIRE MESH CABLE TRAYS.
2. (WMSBKIT620S) BOLT KIT INCLUDED.

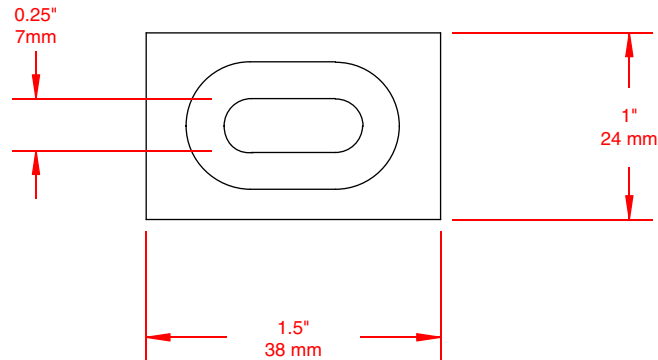

THIS DOCUMENT CONTAINS PROPRIETARY INFORMATION AND IS THE PROPERTY OF CHALFANT MANUFACTURING COMPANY. THE CONTENTS OF THIS DOCUMENT SHALL NOT BE DISCLOSED, COPIED AND OR PUBLISHED WITHOUT THE WRITTEN CONSENT OF CHALFANT MANUFACTURING COMPANY.

<b>FILENAME:</b> CDWMBS		 50 Pearl Rd, Brunswick, OH. 44212 Phone: (800) 365-0228 Fax: (330) 273-8149 www.chalfantcabletray.com	<b>BARRIER STRIP CLAMP</b>
<b>SCALE:</b> AS NOTED			
<b>DRAWN:</b> J.A.B.	01/22/01	<b>PART NO. : AS IN TABLE</b>	
<b>APPROVED:</b>	C.D.: 0151		
<b>REV.</b>		<b>SHEET 1 OF 1</b>	<b>DRAWING NO. : WMBSS</b>